

Study Paper

On

G.fast

By

**Ram Krishna, DDG (FA), Sidh Kumar, Dir (FA),
D. L. Mense, ADG (FA-I) & Avadhesh Singh, ADG (FA-II)**

Table of Contents

Para No.	Contents	Page No
	Abstract	1
1.0	Background	1
2.0	Introduction	2
3.0	Migration to G.Fast	3
3.1	Hybrid Fiber-Copper-Based Broadband Access Network	5
3.2	Backhaul Solutions	6
3.3	A Throughput Prediction	8
3.4	Regulatory and Legal Aspects	8
3.5	Crosstalk in G.fast	12
3.5.1	Near end cross talk (NEXT) and far end cross talk(FEXT)	12
3.5.2	Wideband Crosstalk Modeling	13
4.0	Technology	14
4.1	Modulation	14
4.2	Duplex	15
4.3	Channel Modeling	15
4.4	Channel coding	15
4.5	Bonding	16
4.6	Vectoring	16
4.7	Phantom pair mode	18
4.8	Framing	19
4.9	G.fast Management	20
5.0	Deployment Scenarios	21
5.1	Fiber To The Home vs. Single Port FTTdp	21
5.2	Multi-Port FTTdp and Fiber To The Building	22
5.3	Fiber To The Curb with G.fast	23
5.4	Deployment status worldwide	24
8.0	Conclusion	25
	References	26
	Abbreviations	27

G.fast

Abstract

G.fast provides up to 1 Gbps of ultra broadband access to consumers over existing copper telephone wiring by moving the broadband connections to the distribution points that are close to the home. 'G.fast' is an acronym for *fast access to subscriber terminals (FAST)* and the letter **G** stands for the ITU-T G series of recommendations. **G.fast** is a digital subscriber line (DSL) standard for local loops shorter than 500 m, with performance targets between 150 Mbit/s and 1 Gbps, depending on loop length. High speeds are achieved only over very short loops. Although G.fast was initially designed for loops shorter than 250 meters, Skipio in early 2015 demonstrated G.fast delivering speeds over 100 megabits nearly 500 meters. Formal specifications have been finalized as ITU-T **G.9700** and **G.9701**. Development was coordinated with the Broadband Forum's FTTdp (fiber to the distribution point) project.

1.0 Background:

The demand for higher data rates is continuously increasing necessitating the improvements of the existing network architecture. There are governmental programs for Broadband coverage. Applications like Cloud Computing, Video Streaming, Big Data etc. have contributed significantly to drive these demands. In addition, strong competition of cable network operators has increased the pressure on traditional network operators to deliver high speed services. But a pure fiber network will cause very high costs to be built today at a large scale. During the transition from copper-based access networks to pure fiber networks, the fiber network is gradually extended to bring them closer to the subscribers.

A dense fiber network, where the fiber ends very close to the subscribers and the remaining gap is closed using copper wires, requires introducing a new network node, the distribution point (DP). At this point, the fiber is connected to a small number of copper pairs using an active device called the **DP box**. Fiber to the distribution point (FTTdp) provides new solutions between the existing fiber to the home (FTTH), fiber to the building (FTTB) and fiber to the cabinet (FTTC) topologies. In many cases (such a dense population, trenching cost, rocky terrain) it is not favorable to connect the fiber directly to the customer premises. The copper wires between the DP and the customer premises may be low quality telephony cable bundles with wire pairs for multiple subscribers. The most critical feature of the DP box is its power consumption and a suitable method to supply the device with power. With the idea of reverse power feeding (**RPF**), the problem of supplying the DP box with power can be solved. However, this creates new challenges as the energy budget for a reverse powered DP box is very limited.

2.0 Introduction:

One can deploy wireless technologies (i.e. small cells) but why not make use of existing copper infrastructure, there where available. The evolution of so-called "copper-extending

technologies” encompasses today VDSL2 (with or without vectoring) and tomorrow G.Fast (with or without vectoring). G.Fast stands for the latest transmission technology over twisted pair, capable of delivering more than 1 Gbps over limited distance of approximately 100 meters. In that light, a new architectural definition appears in the market: “Fibre-To-The-distribution point” or FTTdp, distribution point being the location of the transition between fibre and copper (Figure-1).

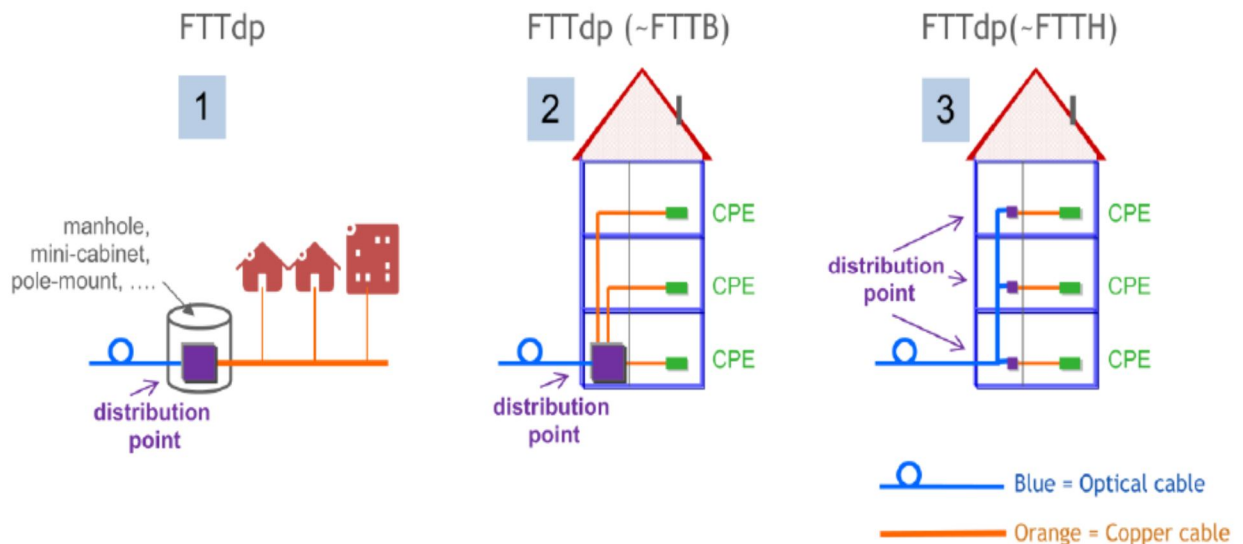

Figure-1. Distribution point being the location of the transition between fibre and copper

As depicted in Figure-1, this distribution point can be found at 3 distinct locations:

1. In a manhole, pole or mini-cabinet at approximately 100 to 200 meters from the customer
2. At the entrance (inside or outside) of the building
3. At the stage of the building very close to the apartment door

As shown in Figure-2, G.Fast is the next high speed transmission technology over copper twisted pair, delivering up to 1 Gbps to the subscriber, available for public trials today and standard have been finalized by ITU-T in December 2014 (ITU-T G.9700 and G.9701). For reaching speed up to 1 Gbps, G.Fast is making use of higher frequencies (106/212 MHz), limiting the distance of transmission to maximum 250 meters, due to strong attenuation (less than 100 meter recommended to go beyond 500Mbps). Today, for FTTdp architectures, one can deploy VDSL2, and G.Fast.

For Fibre-To-The-Cabinet/VDSL2 deployments nowadays, one can introduce vectoring technology to significantly reduce crosstalk between copper pairs in the binder and restore the bandwidth availability to as if the subscriber was the only one in the binder, in other words without any crosstalk at all. Moving fibre even closer to the customer (FTTdp), G.Fast can be deployed on distinct pairs in the same binders, also here vectoring can be introduced to significantly reduce the crosstalk and increase the available bandwidth to the subscriber. Summarizing, deploying fibre closer to the premises and reusing copper (G.Fast) allows to over-come the “last drop challenges” (including associated costs):

- Processing and timing for rights of way, especially in shared private properties
- Convincing customers to switch to a new infrastructure (and a new offer)

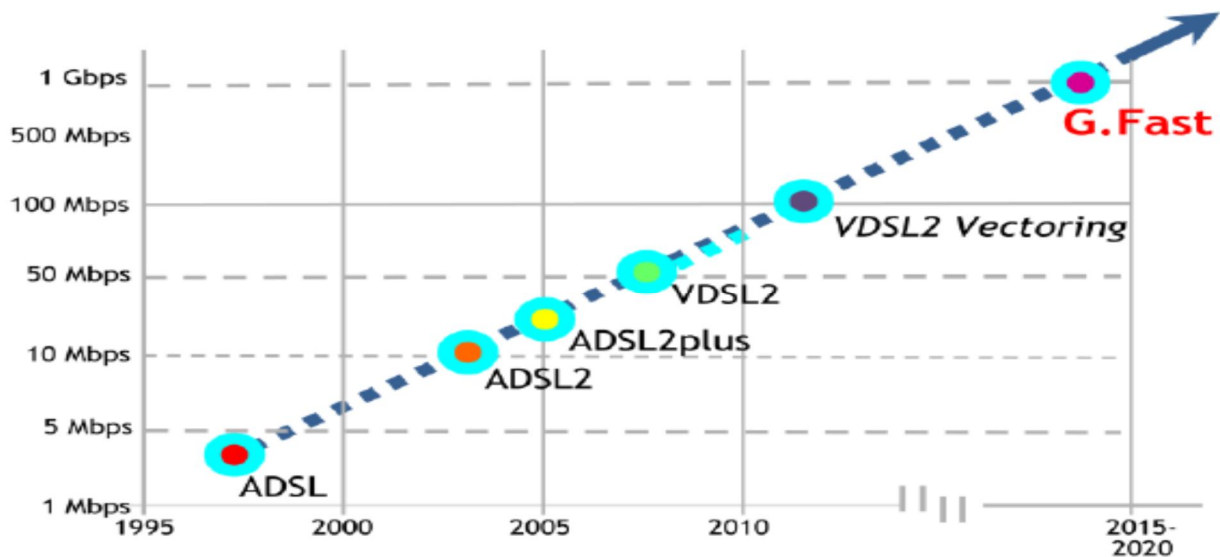

Figure-2. High speed transmission technology over copper twisted pair
(Source: G.fast, Fibre to the Home, Council Europe)

Powering of the equipments can be easily done in “reverse” mode (endorsing power from the end-customer) or in “remote mode” (endorsing power from the network over existing copper wires).

G.fast technology will use the 106 MHz frequency band in the initial stage and 212 MHz in future. The wider the frequency band, the higher bandwidth G.fast can achieve. However, higher frequencies also mean shorter transmission distances, higher costs, and greater power consumption. The frequency band that is ultimately used is a compromise between performance, costs, and implementation.

3.0 Migration to G.Fast:

During the last two decades, two generations of broad-band access systems for telephone loops were deployed:

Generation 1, which is mainly based on integrated services digital network (**ISDN**), and is characterized by systems deployed from the central office. Generation 1 marked the start of data communication beyond dial-up modems,

Generation 2 which is mainly based on asymmetric DSL (**ADSL**) is also characterized by systems deployed from the central office. Generation 2 added a “real” transport network and user bandwidths that are comfortably greater than voice band modems.

Generation 3 (third-generation broadband access system) — the very-high-bit-rate DSL (VDSL) family — that will provide customer data rates of up to 100 Mbps.

Whereas ADSL operates from the central office, often over cables that are several kilometers long, VDSL is designed to operate over shorter loops. Therefore, the VDSL equipment is normally placed in cabinets, resulting in a typical loop length that is below one kilometer. The backhaul solution, namely, the technology to bring data between the transport network and the cabinet, is almost exclusively based on optical fiber technology today.

The transition from the second generation to the third generation thus implies an extension of the fiber network from the central offices to the cabinets. This is a first and fundamental step toward building a large-scale fiber-to-the-home (FTTH) infrastructure.

Generation 4: The fourth generation, presented is the logical extension of the thinking behind Generation 3. The communication requirements of the future assumed to require data rates around 100 Mbs to around 1 Gbps.

To deliver these data rates using the in-place copper architecture requires even shorter loops. The key question is whether or not there exists a natural place to deploy the new transmission equipment in an economical fashion.

With the fourth generation broadband (4GBB) concept, “last” distribution point (DP) is presented as a candidate from which broad-band services could be delivered in a technically and economically feasible fashion. The copper plant is a star network, forking out into finer and finer segments (fewer and fewer lines running together) until eventually individual twisted pairs reach their respective user premises. The last DP can be found by following the lines from the users’ homes and backwards into the network, where normally after 20 to 200 m we find a point in which a number of lines merge together and form a bundle. This is the most outward point at which a modem pack can be installed serving a number of customers, for example, 10 to 30.

The last DP was considered as early as 1990, in the form of fiber-to-the building (FTTB) and fiber-to-the-curb (FTTC) discussions, but at the time it was not associated with a corresponding new generation of copper-access (DSL) equipment making full use of the greater band-width offered by the shorter loops. The earlier FTTB and FTTC discussions left few marks in the standardization processes and were essentially abandoned. We believe that it may be time to develop the idea of moving to the last DP, but now dressed in modern technology and based on twenty years of experience from the development of the broadband market.

A natural question is, of course, how much this infrastructural quantum leap will cost, especially in comparison with installing optical fibers all the way out to the customer, that is, fiber-to-the home (FTTH).

In Fig. 3, the principle deployment history for broadband access equipment is illustrated. The classification of systems as generations in Fig. 3 is introduced to define and emphasize a gap in the foreseen broadband evolution and is not a generally accepted terminology. The term broadband access equipment, for example, loosely denotes communications equipment that is intended for Internet access with a permanent connection, that is, post dial-up systems.

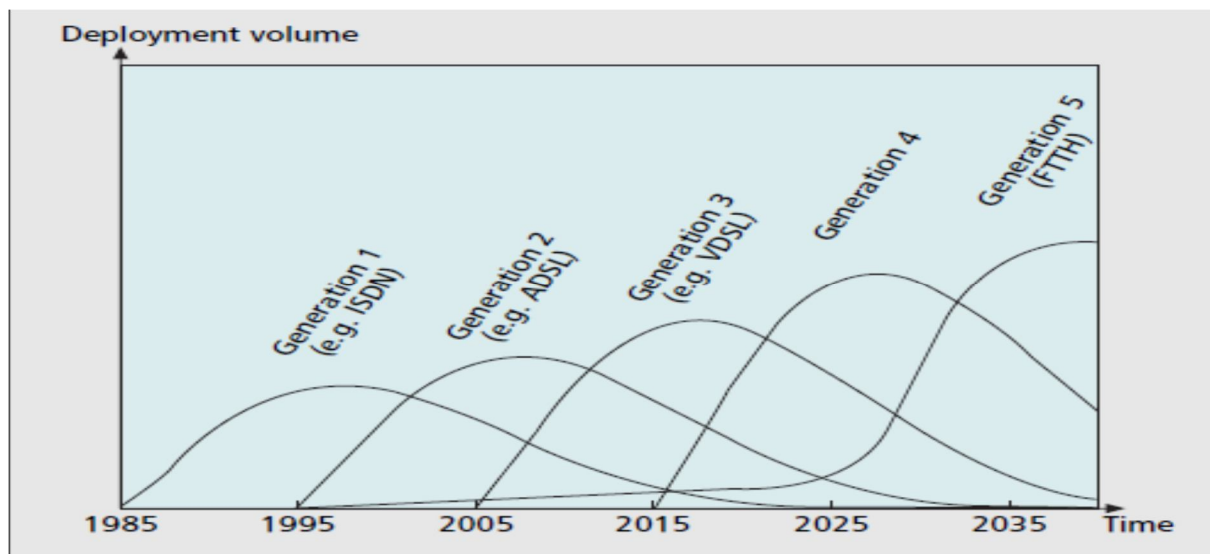

Figure 3. A sketch of deployment volumes of broadband access techniques (number of new installations or upgrades per time unit). The time axis is based on historical data (up to present time), while the y-axis is no more than an illustration of trends.

(Source: Fourth Generation Broadband Concept, IEEE Communication Magazine, January 2009)

Figure 3 contains **historical data** for *Generations 1 to 3* and **predictions** of the deployment timescale for the fourth and the fifth generation broadband. So far, the transition between any consecutive pair of earlier generations has taken about ten years. This suggests that the process that leads to the creation of a new generation broad-band has a period of ten years, based on the lead time in standardization and product realization.

The supported data rate increases by roughly an order of magnitude from generation to generation. This also applies to the step from voice-band modems, which can be viewed as **Generation 0 to Generation 1**. The step to fourth generation broadband (4GBB), using the last DP and possibly, vectoring technology, will provide data rates on the order of 1 Gbps, that is, 10 times the data rate of **Generation 3** (e.g. VDSL2 with up to 100 Mbps).

Applying the above argument to 20 years from now, the bandwidth demand by then should increase another order of magnitude to 10 Gbps per household, serving as a view toward the technical specifications of **Generation 5** — FTTH. According to the prediction in Fig. 3, the deployment volume of the fifth generation gradually will increase, exhibiting a peak around 2035.

3.1. HYBRID FIBER-COPPER-BASED BROADBAND ACCESS NETWORK

In most operational telecom networks, the topology of the access loop looks like the example network situation depicted in Fig.4, where one primary cable connects the central office (CO) to various street cabinets (in the block labeled DP in CAB, meaning distribution point in cabinet), and from there, stepwise forking out to reach the users premises.

The average length of a copper pair, connecting the customer with the CO, ranges from 1.5 km to 3 km depending on country and area. This distance is the main obstacle to increasing the bandwidth from **Generation 2** systems. Where best-in-class is ADSL2+ — in practice, normally providing between 10 and 20 Mbps to the higher bit rates offered by **Generation 3** — today, VDSL2 provides up to 100 Mbps per copper pair.

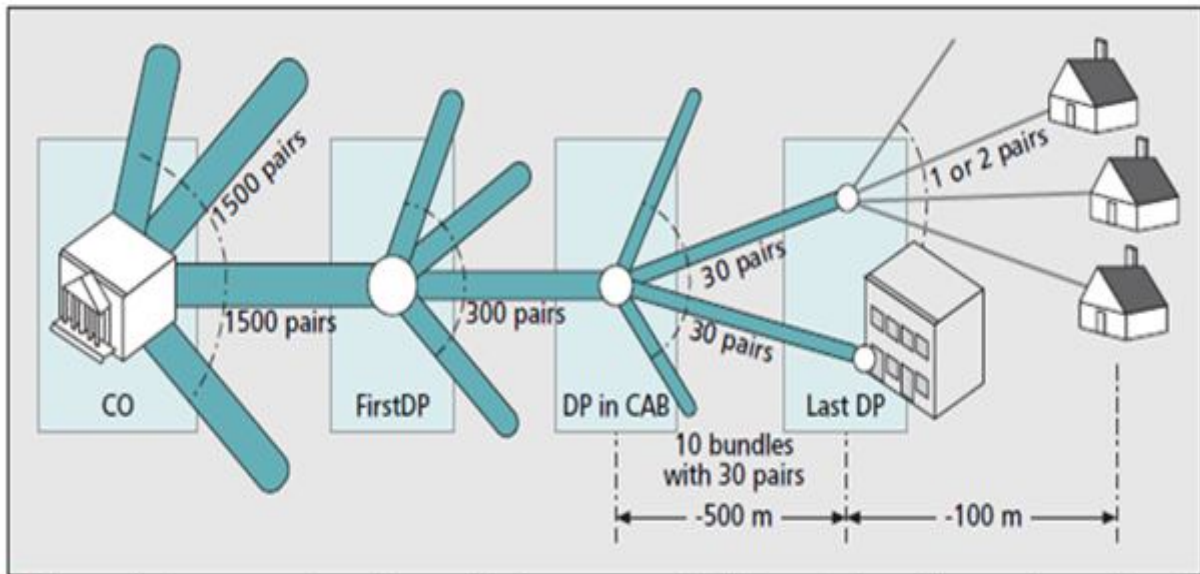

■ **Figure 4.** Access network topology and deployment scenario. This particular cable serves the outskirts of a small city in Sweden.

By placing the transmission equipment in cabinets, it is possible to reduce the average length to less than 1 km (Fig. 4). Then, the cabinets typically are connected to the CO using optical fiber and to the users with VDSL2.

The 4GBB is the next logical step to shorten the loops, increase the bandwidth, and extend the optical-fiber access network. The transmission equipment then would be placed in the last DP, labeled as Last DP in Fig. 4, and typically connected to the CO with newly deployed fiber. The user still will be linked to the last DP by means of a copper pair.

The alternative to the concept of 4GBB described here is to deliver the fiber all the way out to every customer, that is, FTTH. The problem with all deep-fiber strategies, and the reason why the technique is detained, is the cost of deploying the fiber.

According to the techno-economic investment evaluations in the deployment of FTTH can be justified only in particularly dense urban areas, whereas the cost of deploying fiber to the last DP is moderate. As a rough estimation, using the example of Fig. 2, replacing the copper from the cabinet to the last DP will imply digging 5 km (500mX10 bundles), whereas replacing the cabling from the last DP to each house will mean an additional 30 km/cabinet.

3.2. BACKHAUL SOLUTIONS

The connection between the 4GBB equipment and the CO can be realized in more ways than using optical fiber. Although this is not central to the 4GBB concept, it is a field of possible innovation.

If the 4GBB concept was to be deployed today, it is likely that a passive optical fiber network (PON) architecture (Fig. 5) would offer the most cost-effective solution. This solution could be reasonably “future proof” in that, without additional investments in fiber, the optical

transmission equipment could be upgraded, for example, from gigabit-PON (G-PON) to 10G-PON, when such new technology becomes available.

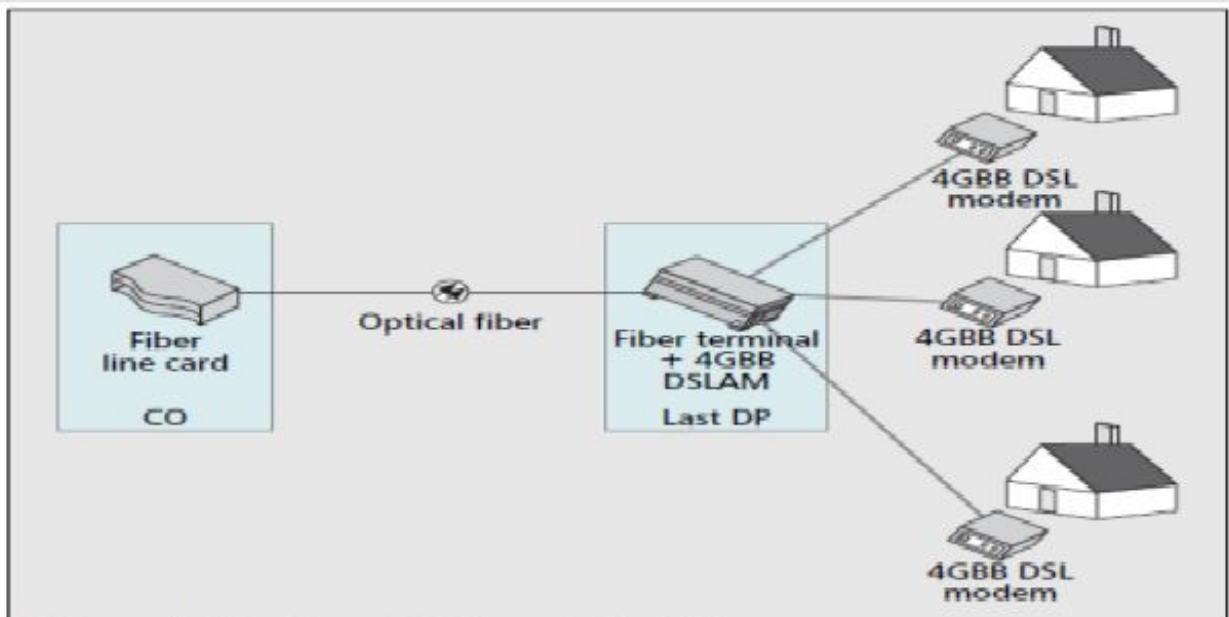

■ **Figure 5 .** *Topology with fiber to the last DP.*

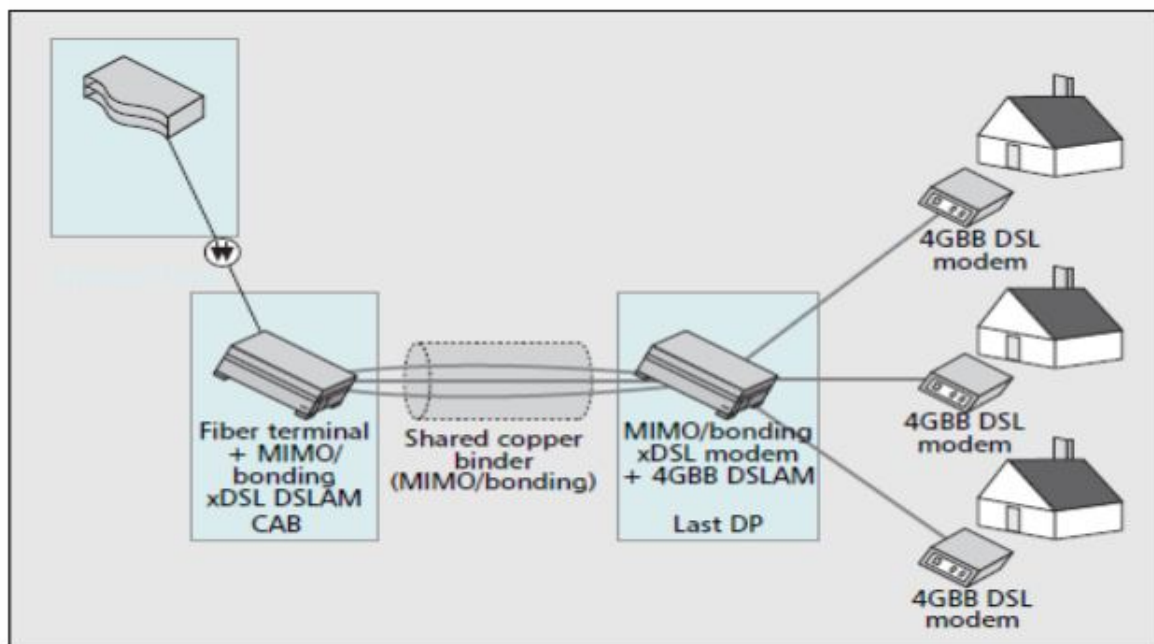

■ **Figure 6 .** *Topology where a shared copper binder is used between cabinet and last distribution point.*

However, it could become an option to use the **copper binder** between the **CO and the last DP** as a backhaul solution (Fig.6), thereby avoiding or postponing the cost of digging. With multiple-input multiple-output (MIMO) schemes applied to cancel crosstalk and spatially correlated noise, our 30 pair binder could be converted to a 60X60 or 59 X 59 MIMO channel depending on whether or not the binder shield can be used. Such a copper backhaul solution could be suitable for shorter ranges, for example, supporting several Gbps from the cabinet to the last DP. This scheme then would be similar to the copper alternative (Cu)PON concept

proposed, in the sense that the copper is shared, but different in the sense that we use the shared DSL system only for the backhaul from the cabinet to the last DP. An interesting side effect of this solution is that the 4GBB equipment at the last DP could be powered on the same copper wires as used by the MIMO binder.

3.3. A THROUGHPUT PREDICTION

The previous section established the feasibility of the new 4GBB hybrid fiber-copper topology at an affordable cost of investment per customer. This section presents a projection of the achievable throughput connecting the last DP and the customer.

Electromagnetic compatibility of interacting equipment and services imposes major limitations for the achievable data rates. Data transmission over wires causes radiation and potentially disturbs nearby equipment. This undesirable effect is referred to as *egress* and limits the applicable transmit power spectral densities (PSDs). Reversely, cables, in particular aerial drop wires, pick up extrinsic disturbances (generated outside the cable), referred to as *ingress*. Lacking dedicated ingress and egress regulations, we derive realistic ingress levels and transmit PSD masks from ingress and egress limits defined in the existing international standard on radio interference, hereafter referred to as CISPR-22. Together with wideband cable models, these transmit PSDs, and the ingress levels provide the basis for throughput predictions.

3.4. REGULATORY AND LEGAL ASPECTS

Ingress and egress mechanisms, described in, can be roughly described as follows: transmission of data over a wire pair is performed by differential excitation of the pair (i.e., excitation of the circuit formed by the two wires of a pair). Due to the imperfection of the geometrical and consequently, also of the electrical, symmetry of each wire pair with respect to the earth, the differential signal causes a corresponding common-mode excitation of the wire pair (i.e., excitation of the circuit formed by the wire pair constituting a single conductor and earth). The pair of wires then acts as a transmit antenna and causes unwanted **egress**. The degree of symmetry (or asymmetry) causing the differential-mode to common-mode conversion, an important property of a wire pair or a cable, is referred to as *balance* and quantified by the ratio of the corresponding voltages or currents. Although the balance can reach values around 70 dB in the voice band (i.e., in the kHz range), it decreases significantly with increasing frequency. Extrapolating measurement results collected for frequencies up to 30 MHz, the conservative assumption that the balance decays linearly from 35 dB in the voice band to 25 dB at 100MHz is adopted hereinafter.

Conversely to egress, a time varying electromagnetic field in the vicinity of a wire pair causes a common-mode excitation of both wires with respect to earth. The wire pair simply acts like a receive antenna. The balance, which is a reciprocal property, determines the amount of resulting differential-mode **ingress** caused by common-mode to differential-mode conversion.

As a principal assumption, suggests that an electromagnetic field with electric field-strength x volt/m causes an induced worst case common-mode voltage of x volt — an observation that is based mainly on experience gained through measurements both in the laboratory and in the field. Independent theoretical and experimental work supports this observation to an extent large enough to warrant application for throughput predictions.

In a far-end cross-talk (FEXT)-free environment, a background-noise PSD of -130 dBm/Hz is, though conservative, a widely accepted value for frequencies up to 30 MHz.

Aiming at assumptions that can be referred to as realistic to conservative, a linear transition (in log domain) from the background-noise level at lower frequencies to the CISPR-22 ingress level at higher frequencies is assumed in the range from 10 MHz to 30 MHz. The resulting noise PSD for a FEXT-free environment is shown in Fig. 7 (dotted line).

As discussed in the previous section, the cable segments at the customer end of the access network exhibit short lengths and a low number of pairs. Consequently, it is reasonable to assume that the number of expected cross talkers is low. Apart from the FEXT-free case, a scenario with both ingress and one equal-length FEXT disturber is considered.

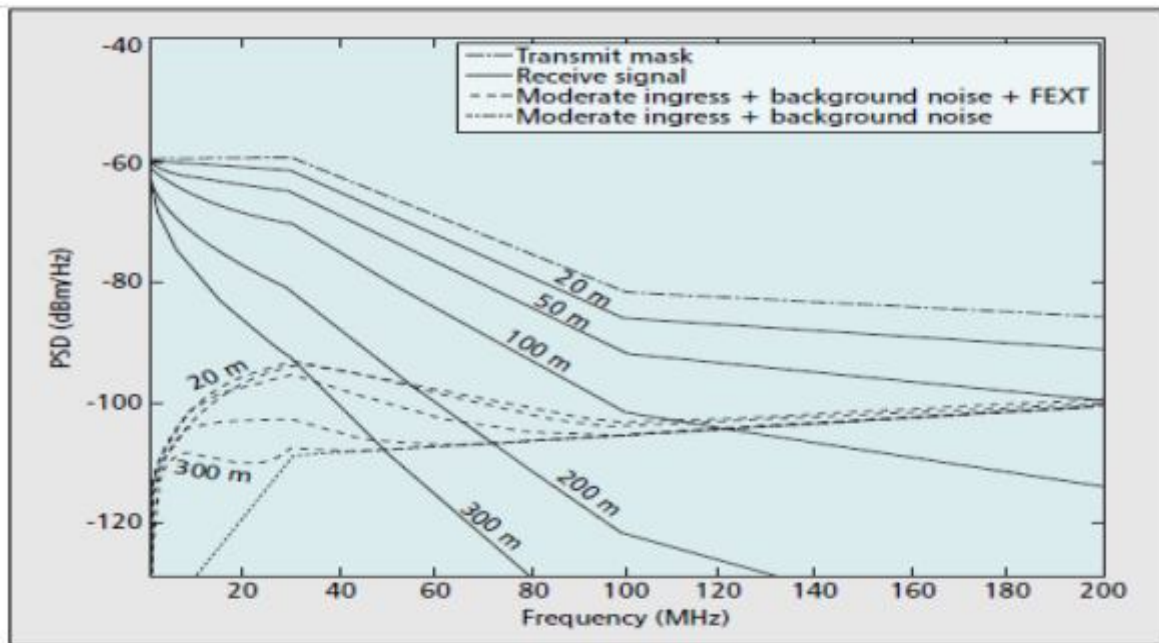

Figure 7 Transmit and receive power spectral densities (PSDs): The uppermost line (dashed-dotted) is the transmit PSD mask, followed by receive PSDs (solid lines) for loop lengths 20 m, 50 m, 100 m, 200m, and 300m (AWG24/0.5 mm). Transmission is impaired by moderate ingress (-110 dBm/Hz), FEXT from one equal-length crosstalker, and background noise (-130 dBm/Hz).

(Source: Fourth Generation Broadband Concept, IEEE Communication Magazine, January 2009)

While FTTH (such as GPON) has widely been projected as the optimal solution for providing Gigabit connectivity, there are still fundamental challenges for operator to lay fibre for those final metres to the subscriber's home. G.Fast is a promising technology that is attracting increasing interest from operators looking to provide FTTH-like speeds without the trouble and cost associated with fibre. G.Fast promise to provide theoretical aggregate upstream and downstream capacity of up to 1Gbps at distances of up to 500m using existing copper phone line infrastructure. G.Fast achieves this by compounding various technologies that improves both speed and reach around VDSL2. This is done by combining technologies such as pair-bonding (bonding two copper pairs together), vectoring (eliminating cross talk or interference between different VDSL2 lines) and phantom mode (creating virtual pairs between copper pairs).

In combination with GPON, the operator now has a more cost effective method of deploying FTTH-speeds to the subscriber's home by deploying fibre up to the last 200m, from which the distribution point can then utilize G.fast to complete the final metres.

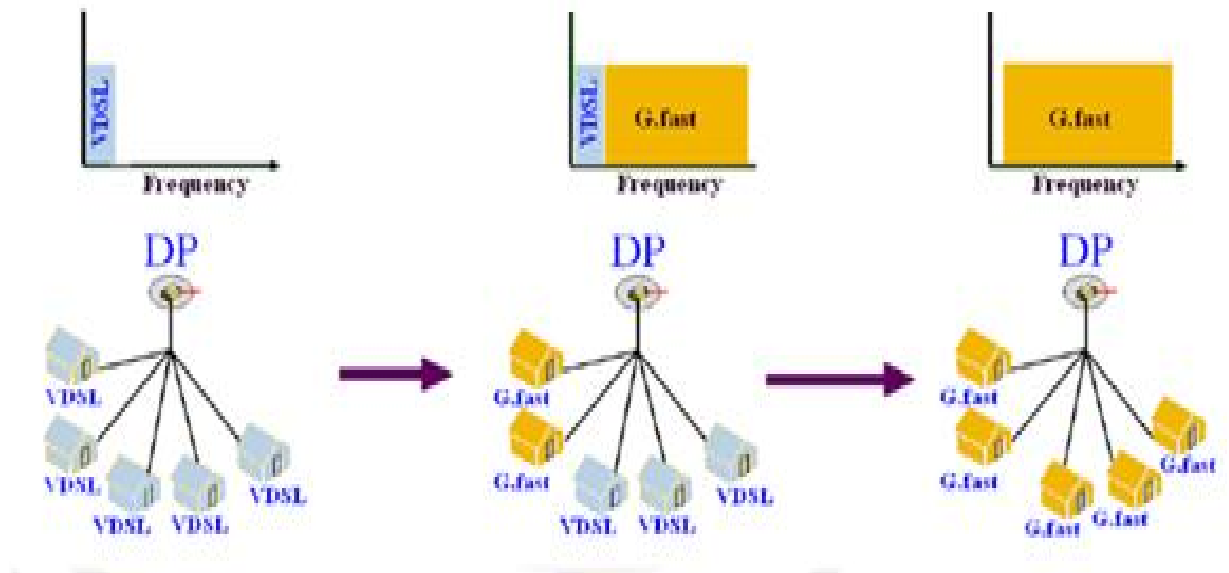

Figure: 8 Coexistence with xDSL: VDSL2 to G.fast migration

Traditional copper networks, which primarily carry voice services, provided data services using dial-up modems and ISDNs in early days. With their limited access rates, traditional copper networks struggled to keep up with the rapidly growing demand for bandwidth driven by data services. ADSL access technology was the first technology to bring people into the broadband access era, with downstream access rates of up to 8 Mbit/s. Later on, ADSL2+ technology extended the signal frequency band from 1.1 MHz to 2.2 MHz and improved the maximum downstream rate to 24 Mbit/s. It replaced ADSL technology and was adopted throughout the industry. Later on, VDSL technology was able to improve on both upstream and downstream rates and make symmetric access possible, which overcame the disadvantage of ADSL2+'s asymmetric access.

However, there arose a dispute between VDSL's two modulation techniques, QAM and DMT, and VDSL was incompatible with ADSL2+. In response, VDSL evolved to VDSL2, which was fully compatible with ADSL2+. VDSL2's access rates of up to 100 Mbit/s transitioned copper access technology into the "Fast Broadband" era. VDSL2 works on both the 17 MHz and 30 MHz frequency band, which can be further divided up into multiple upstream and downstream sub channels, effectively providing even higher bandwidth over short distances. As such, VDSL2 is ideal for short-distance applications such as FTTC (fiber to the cabinet) and FTTB (fiber to the building), whereas ADSL2+ is more suited for DSLAM equipment in central offices.

Although VDSL2 can ideally provide speeds up to 100 Mbit/s, it is challenging for VDSL2 to reach 100 Mbit/s access speeds due to crosstalk between lines. To address this issue, vectoring technology, which can eliminate crosstalk, was developed, raising copper access

speeds to de facto rates of 100 Mbit/s. However, VDSL2 technology is a bottleneck to increasing transmission rates because vectoring technology is both a crosstalk cancelation technology and a VDSL2 technology. The maximum rate vectoring technology can reach is the maximum rate that a noiseless, single copper pair applying VDSL2 can reach.

To help enable copper access to reach 1000 Mbit/s rates, G.fast technology has emerged and will transition copper access into the gigabit era.

Research began on access technologies that enabled ultrahigh speed transmission over short distance twisted pairs to address issues associated with FTTH (fiber to the home) applications. In Europe such as BT (British Telecom) and FT (France Telecom), FTTH found to be expensive to implement in brown fields because of expensive labor, scattered population, problems with home fiber wiring, and slow roll-outs. As an FTTH alternative, European operators chose to lay out fiber to the distribution point (FTTdp) and reuse existing access media, such as telephone lines and coaxial cables, to provide ultra-high-speed broadband access. Because the last-part transmission was over such a short distance, the operators anticipated they could achieve gigabit speeds using existing access media.

To address the last-part transmission issue, G.fast technology was developed. In order to work successfully, G.fast must be capable of ultra-high speeds, which entails extending the frequency spectrum. A wider frequency band results in a higher access speed. VDSL2 currently works on 17 MHz or 30 MHz, while G.fast will work on 106 MHz or even 212 MHz. Of course, the frequency spectrum cannot be extended infinitely. Like spectrum resources in the wireless communication sector, spectrum resources in the fixed communication sector must be properly planned, to prevent conflicts with spectra already in use and to reserve space for future technologies. For example, the Office of Communications (Of com) in the UK has defined a strict ANFP (access network frequency plan) for spectrum application. The ADSL2+ spectrum is allowed only in exchanges, and the VDSL2 spectrum can be deployed only at FTTC street cabinet sites. The G.fast spectrum may need to avoid the frequency bands that are already in use.

G.fast technology uses the same discrete multi-tone (DMT) modulation technology as VDSL2. To address scenarios in which the network is upgraded from VDSL2 to G.fast, but terminals are not, the standard requires that G.fast be backward compatible with VDSL2 CPEs. Operators generally prefer to upgrade their equipment first and then allow end users to use VDSL2 CPEs until they upgrade to G.fast terminals.

Unlike VDSL2, G.fast technology does not use FDD (frequency division duplex). Instead, G.fast uses TDD (time division duplex). In FDD mode, different frequency bands are used for upstream and downstream transmission, whereas in TDD mode, different timeslots are used for upstream and downstream transmission. TDD facilitates hardware implementation and flexible downstream/upstream ratio definition (to establish symmetric access). Reports of G.fast bandwidth exceeding 1 Gbps generally refer to the sum of the upstream and downstream bandwidths.

Running on a very high frequency band, G.fast technology applies only to short-distance transmission. Therefore, G.fast devices reside close to end users and may encounter the power supply issue. To resolve this issue, G.fast devices rely on reverse power feeding. That is, end users terminals supply power to G.fast devices through access media. In addition, G.fast makes use of a range of energy saving technologies, effectively reducing G.fast's power consumption per line less than that of VDSL2 while helping facilitate the implementation of reverse power feeding.

3.5 Crosstalk in G.fast

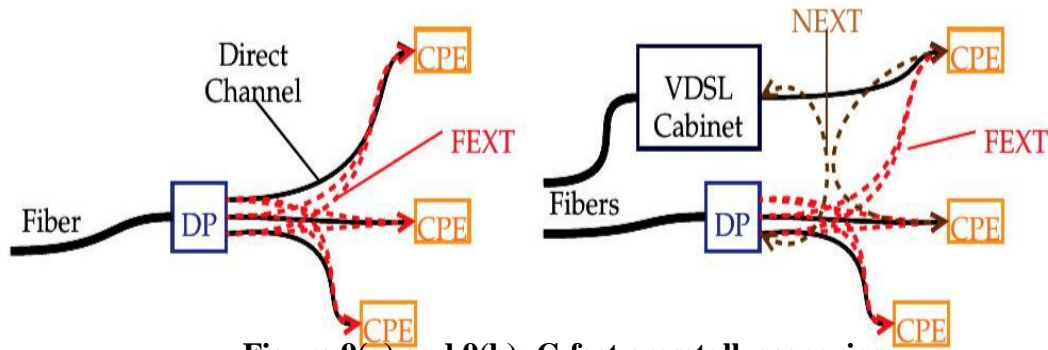

Figure 9(a) and 9(b): G.fast crosstalk scenarios

3.5.1 Near end cross talk (NEXT) and far end cross talk (FEXT) : Crosstalk is present in most G.fast topologies. Whenever multiple subscribers are part of the same cable binder, some portion of the signal from one line disturbs the signals of other lines through the electromagnetic coupling between them. With increasing frequency, the cross-talk coupling between the lines becomes stronger until the crosstalk couplings and the direct connection have the same strength at very high frequencies, which is then very similar to a wireless channel.

We distinguish between two types of crosstalk near-end crosstalk (NEXT) and far-end crosstalk (FEXT). The situation of a binder with G.fast lines only is shown in Figure 9 (a). In this case, only FEXT is present, where the G.fast receivers get signals from the corresponding far-end transmitter, but are disturbed by far-end signals from other lines. NEXT does not exist in pure FTTP scenarios, because the DP synchronizes the transmit signals such that all lines send their downstream and upstream signals at the same time.

Near-end crosstalk, where the transmit signal of one line disturbs the receiver of another line at the near-end, e. g. transmitter and receiver are within the same mini-cabinet, exists for the FTTC scenarios with VDSL and G.fast in the same binder. This is shown in Figure 9 (b). Due to the fact that G.fast uses time division duplexing (TDD) and VDSL uses frequency division duplexing (FDD), a street cabinet DP with both services experience near-end crosstalk in addition to FEXT at the overlapping frequency spectrum.

Good channel models are required to evaluate the effects of crosstalk on the data transmission and to develop appropriate signal processing methods to achieve the highest data rates.

3.5.2 Wideband Crosstalk Modeling

More details are presented in a document named ‘Wideband modeling of twisted-pair cables for MIMO application’^[7], where the detailed description of the channel model can be found. Simulation results shown here are based on the described type of channel model.

Figure. 10 (a) shows one of the measured access cables with ten twisted pairs, organized in five star quads. Measurements are done for frequencies up to 300 MHz to cover the full G.fast frequency spectrum.

Measurement data of transfer functions of this type of cable show that the crosstalk behavior at high frequencies is very different than predicted by crosstalk models like the ATIS model [Jan08]. To reproduce the high frequency behavior in a simulation model, a cable binder is represented in terms of an equivalent circuit that describes direct channels and crosstalk transfer functions of the cable binder. Figure. 10 (b) shows the equivalent circuit as it is proposed .

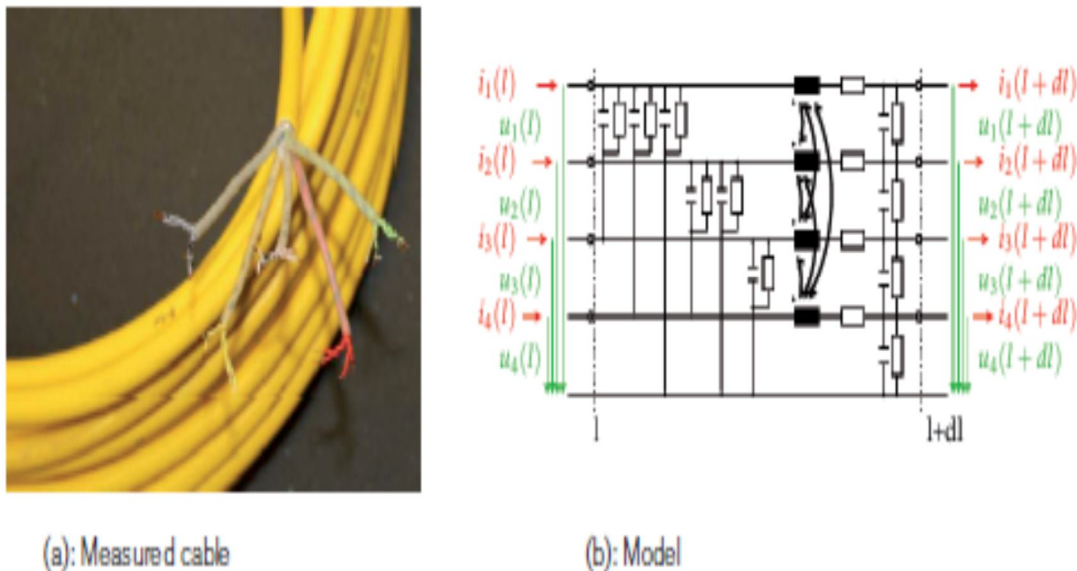

Figure 10(a) & (b): Deutsche Telekom cable and abstract model for G.fast

A comparison between measurements and the model of one of the Deutsche Telekom cables demonstrates the advanced behavior of the new m-MIMO channel model. Figure 11 shows the direct channel and FEXT transfer functions up to 300 MHz.

Important aspects of the crosstalk behavior at high frequencies can now be simulated. The direct channel attenuation (blue) in Figure 11 increases at high frequencies and the transfer function may be even weaker than the crosstalk couplings to other pairs (green). These effects are not covered by other models.

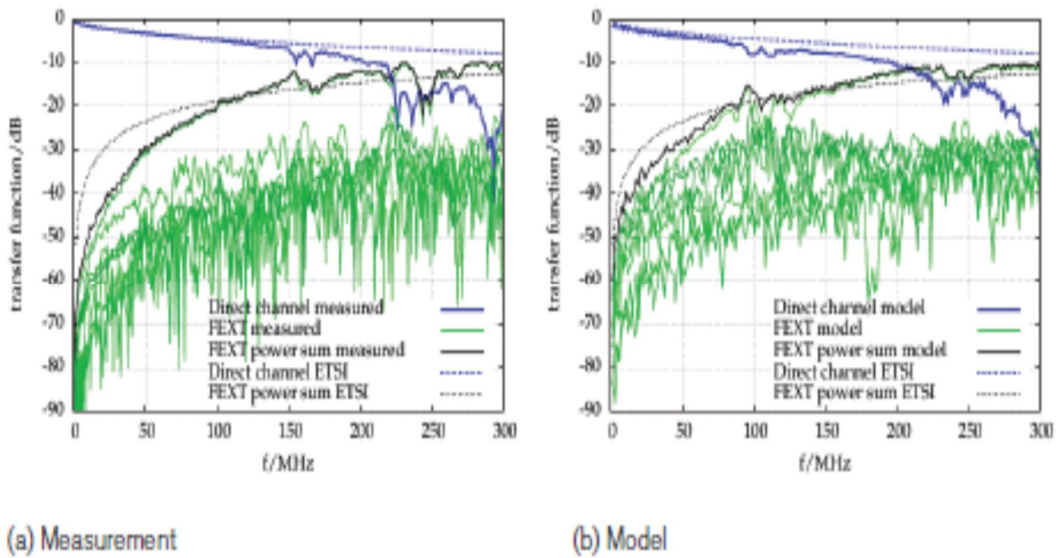

Figure 11(a) & (b): Measurement and model of direct channel and FEXT transfer functions of twisted pair cables up to 300 MHz
 (Source: Wideband Modelling of Twisted-Pair Cables for MIMO Applications, Fig 1 & Fig. 8)

4. Technology

4.1. Modulation

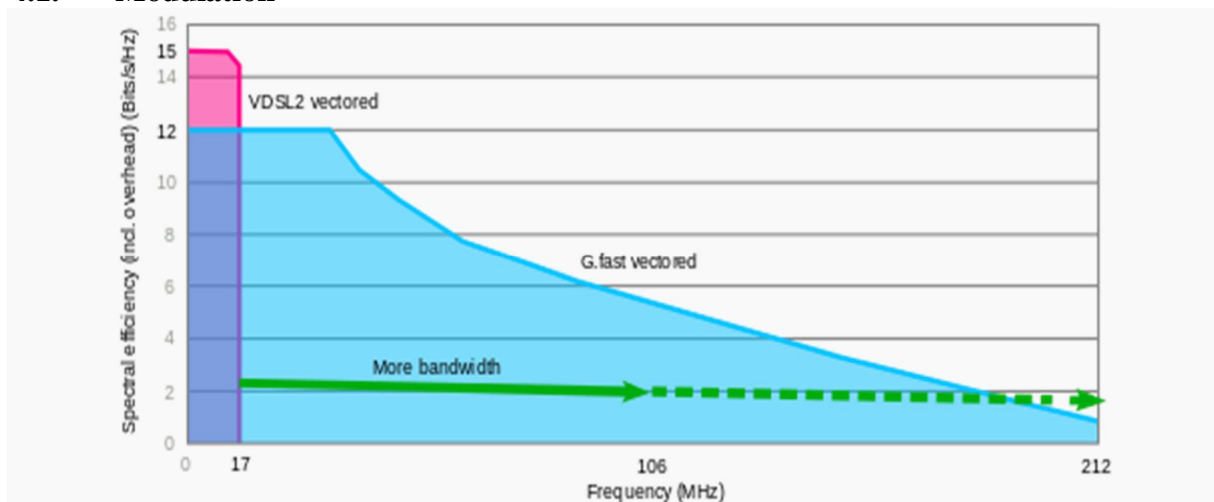

Figure:12 Frequency spectrum of the G.fast standard compared to VDSL2
 (Source: The Numbers are in: Vectoring 2.0 Makes G.fast Faster, Alcatel Lucent)

In G.fast, data is modulated using discrete multi-tone (DMT) modulation, as in VDSL2 and most ADSL variants G.fast modulates up to 12 bit per DMT frequency carrier, reduced from 15 in VDSL2 for complexity reasons.

The first version of G.fast will specify 106 MHz profiles, with 212 MHz profiles planned for future amendments, compared to 8.5, 17.664, or 30 MHz profiles in VDSL2. This spectrum overlaps with the FM broadcast band between 87.5 and 108 MHz, as well as various military and government radio services. To limit interference to those radio services, the ITU-T G.9700 recommendation, also called G.fast-psd, specifies a set of tools to shape the power spectral density of the transmit signal; G.9701, codenamed G.fast-phy, is the G.fast physical layer specification. To enable co-existence with ADSL2 and the various VDSL2 profiles, the start frequency can be set to 2.2, 8.5, 17.664, or 30 MHz, respectively.

4.2. Duplex

G.fast uses time-division duplexing (TDD), as opposed to ADSL2 and VDSL2, which use frequency-division duplexing. Support for symmetry ratios between 90/10 and 50/50 is mandatory, 50/50 to 10/90 is optional. The discontinuous nature of TDD can be exploited to support low-power states, in which the transmitter and receiver remain disabled for longer intervals than would be required for alternating upstream and downstream operation. This optional discontinuous operation allows a trade-off between throughput and power consumption.

4.3 Channel Modeling

The parameters of the channel model are selected to match the properties of different network topologies. Tab. 1.0 summarizes the main properties of different network topologies as mentioned before. The naming in standardization documents such as [Bro10] or [Bro14] can be different.

Topology	Line length	Binder Size	Power Supply	Crosstalk Environment
1-port DP	1m..100m	1 pair	RPF	No crosstalk
Multiport-DP	10m..250m	1 to 16 pairs	RPF	Self-FEXT
FTTC	50m..300m	up to 48 pairs	RPF or local supply	Self-FEXT and alien crosstalk

Table 1: Properties of different FTTdp network topologies

There are different types of channel models for twisted pair copper wires available, which have been used to develop xDSL technologies. There are single line models like the ETSI model and MIMO models for crosstalk modeling like the ATIS model.

But they are not sufficient for FTTdp channel modeling, because they do not cover the G.fast frequencies up to 212MHz. Measurements at high frequencies show a demand for improved channel models because of several behavioral aspects of the cables which are not covered by present models.

4.4 Channel coding

The forward error correction (FEC) scheme using trellis coding and Reed-Solomon coding is similar to that of VDSL2. FEC does not provide good protection against impulse

noise. To that end, the impulse noise protection (INP) data unit retransmission scheme specified for ADSL2, ADSL2+, and VDSL2 in G.998.4 is also present in G.fast. To respond to abrupt changes in channel or noise conditions, fast rate adaptation (FRA) enables rapid (<1 ms) reconfiguration of the data rate.

4.5 Bonding

Bonding uses two copper pairs from the DSLAM to the residence and joins them logically at the data layer as one pipe. Doing this almost doubles the bit rate, and is a standardized technique that applies to both ADSL and VDSL. The very flexible technology can deal with two quite different loops: up to a 4:1 bit rate delta on the pairs can be supported. This is not a typical deployment scenario, however, and would likely occur where something is unusual on the “second loop”—perhaps it is much longer, or perhaps it has some impairments.

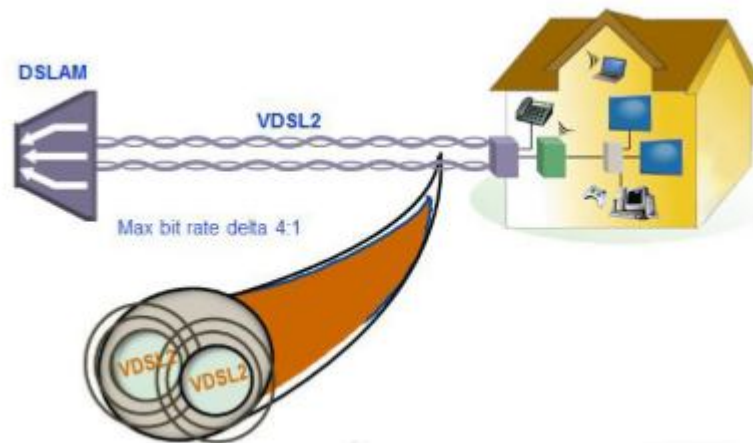

Figure:13 G.fast Bonding

The ITU has standardized bonding in the G.998 (or G.bond) series. Standards include:

- G.998.1 — ATM-based multipair bonding
- G.998.2 — Ethernet-based multipair Bonding (ADSL2+, VDSL2)
- G.998.3 — Multipair bonding using time-division inverse multiplexing

4.6 Vectoring

Vectoring is focused on eliminating the impact of far-end crosstalk (FEXT) within the binder group. The following section discusses the technology in detail. DSL-based service involves multiple pairs in a binder group, all carrying DSL signaling. This signal energy radiates outside its pair and is picked up as noise by adjacent pairs. Far end crosstalk (FEXT) significantly reduces bit-rate performance compared to FEXT-free performance. A technique has recently been developed, called vectoring, which can significantly improve bit-rate performance by canceling the FEXT impact. This technique has been standardized by the ITU in the G.993.5 series and is widely available in the DSL vendor community.

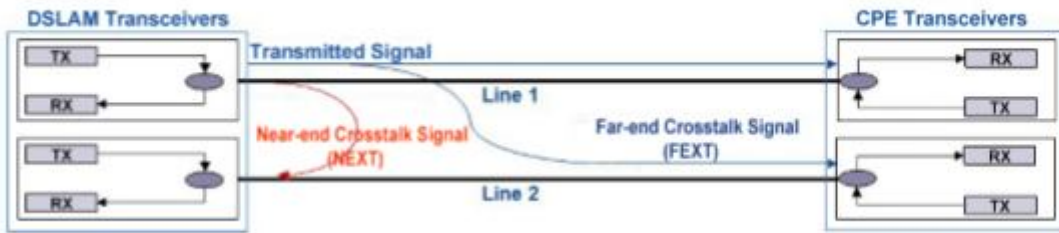

Figure:14 Cross talk

In the VDSL line cards, a VTU-O VDSL circuit receives the downstream data stream and processes it through a symbol encoder. This output is then processed by the output modulator and this signal is then coupled to the physical loop copper cable pair. In a vectoring design, a pre-coder function is added as shown below.

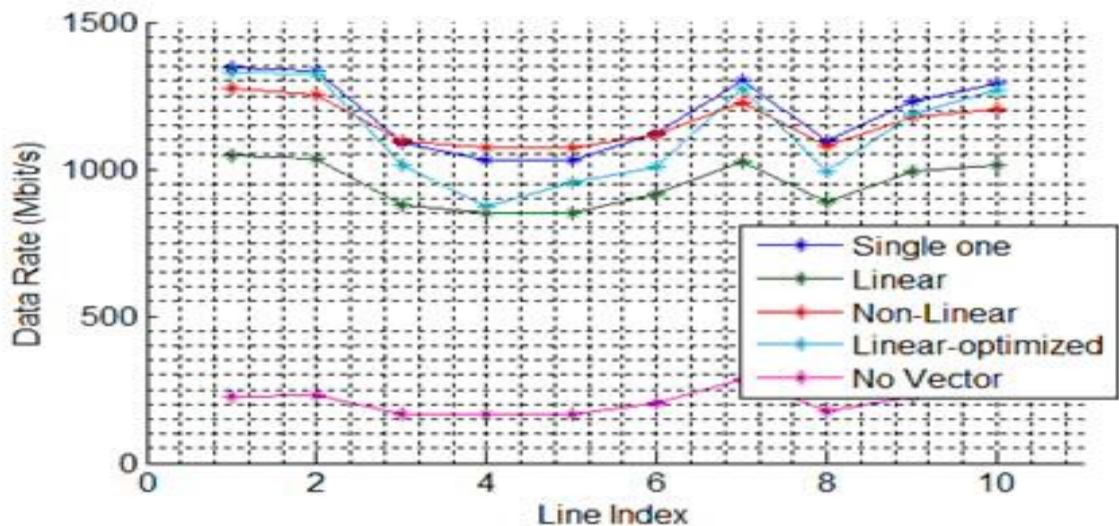

Figure 15 G.fast simulation results over 100-meter lines

(Source: G.fast: Moving Copper access into the Gigabit Era)

Similar to VDSL2, G.fast performance is affected by crosstalk between lines. Without the vectoring noise cancellation process, G.fast rates are severely degraded. Figure 15 illustrates simulation results of G.fast rates over 100 meter lines. Some lines are capable of up to 1.3 Gbps. If crosstalk is present and vectoring processing is absent, the G.fast rate drops sharply to about 200 Mbit/s. This occurs because G.fast operates at a very high frequency and the impact of crosstalk on G.fast is much more severe than on VDSL2. Therefore, G.fast must use a more advanced vectoring technology to cancel crosstalk between lines.

Two vectoring options are currently available for G.fast: the **improved linear pre-coding algorithm** and the **non-linear pre-coding algorithm**. The later obtains more gain than the former on high frequencies but obtains almost the same gain as the former on low

frequencies. We can see in Figure 15, that on the majority of lines, the rate achieved using the non-linear algorithm is higher than that achieved using the linear algorithm. However, due to its complexity, the non-linear algorithm requires a more powerful processor than the linear algorithm, which results in implementation difficulties, high power consumption, and more costs. As such, the first release of the G.fast standard uses the improved linear precoding algorithm.

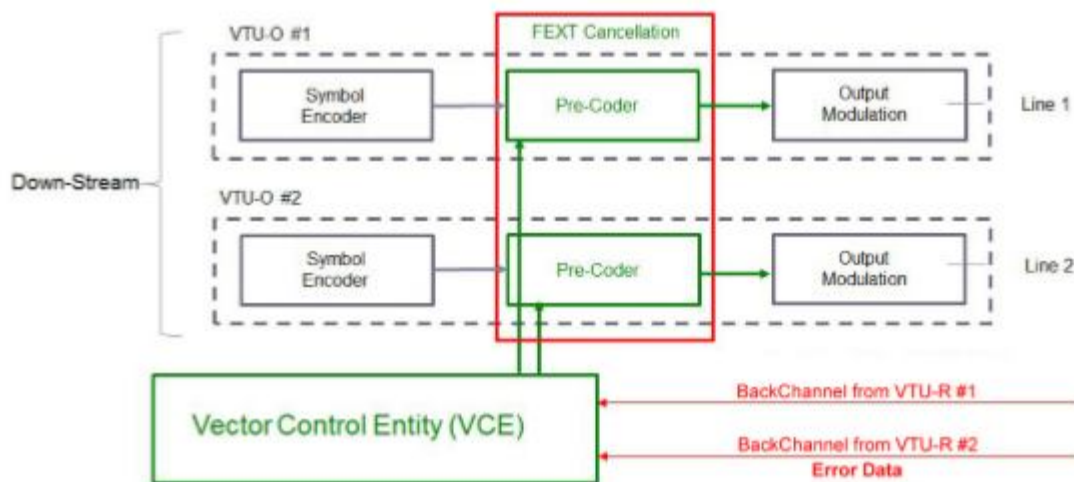

Figure 16. G.fast vectoring

The far-end VTU-R in the CPE receives a special pilot tone sequence of sync symbols and quiet symbols sent from the VTU-O for each discrete multitone (DMT) subcarrier. The VTU-R computes an error sample for each tone. This is, effectively, a vector data noting where the received QAM constellation was positioned when received versus where it should have been. The receiver says, “when you sent me the data, you said it should be here, but I didn’t receive it here, I received it over there.” There is a displacement. The VTU-R uses a special, back-channel communication path to send this error sample data upstream to a vector control entity (VCE). The VCE is a new computing entity within the DSLAM that receives the error sample data from all of the lines in a vector control group. It calculates a channel matrix and associated FEXT coefficients from the received data. This data is used by a new pre-coder function to modify the output signal modulation. Through this process, the output signal is changed to anticipate how the receiver will be impacted by crosstalk. The modified signal “cancels” the crosstalk impact.

4.7 Phantom Mode DSL

This technology adds a virtual, phantom pair to two copper pairs. The two typical DSL copper pairs operate in a differential mode, while the third signal is injected in common mode via a passive coupling device. Thus, phantom mode, indicated below, adds a “third pair” data path without having to add a third copper pair.

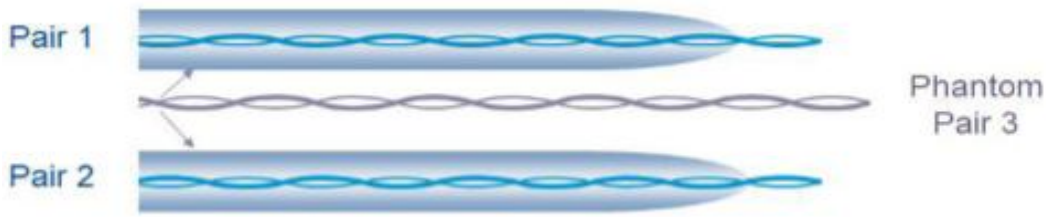

Figure 17. Using a common-mode signal injection to create a third, phantom pair.

Figure 18 shows a standard line card with three ports. Ports one and two are wired up to the actual copper, while the third port is wired to a passive coupling device. This device, which is not powered, injects the common mode signal. It can be located away from the DSLAM line card, providing deployment flexibility. Data from port three rides across the copper in the phantom configuration. This means that the CPE must be changed to accommodate the new design, but this can increase data throughput significantly. Common mode is less sensitive to NEXT/FEXT, but it injects noise into the differential mode lines 1 and 2. Vectoring is thus required to reduce crosstalk in the bonded group.

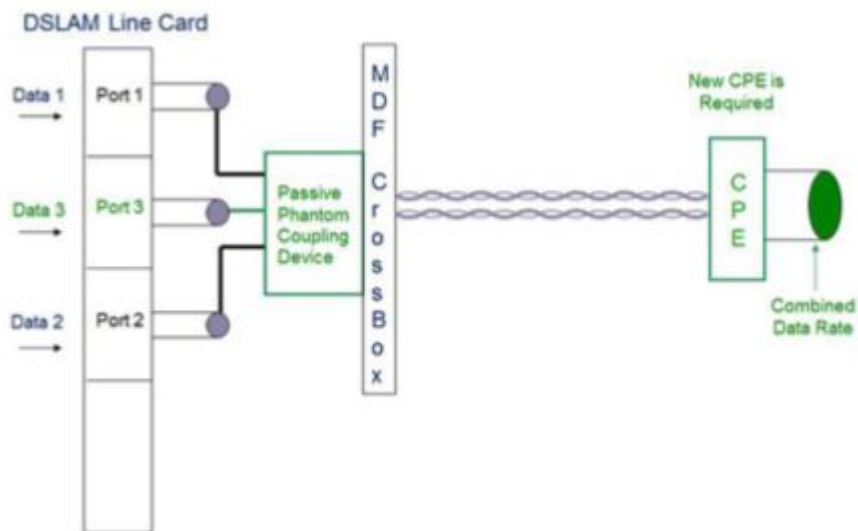

Figure 18. phantom-mode DSL.

4.8 Framing

The frame structure of G.fast is different to VDSL due to TDD. Fig. 19 illustrates the G.fast frame structure. The data is organized in superframes, where each superframe starts with a sync frame that is followed by multiple data frames. The default setting is a superframe that consists of 8 TDD frames.

Each TDD frame has the length of an integer number of DMT symbols. It contains a group of downstream symbols and a group of upstream symbols as well as guard times between upstream and downstream data. Both guard times of a TDD frame sum up to the length of one DMT symbol in time.

Furthermore, each TDD frame contains an RMC (robust management channel) symbol for fast reconfiguration and physical layer management. The TDD sync frame contains a sync

symbol for channel estimation and synchronization. As shown in Figure. 19, there are two definitions of the TDD frame. The physical TDD frame consists of one downlink and one uplink symbol block and starts with the downlink data block. The logical TDD frame for sync frames starts with the sync symbols and for other TDD frames it starts with the RMC symbol which is somewhere in the middle of the downstream data.

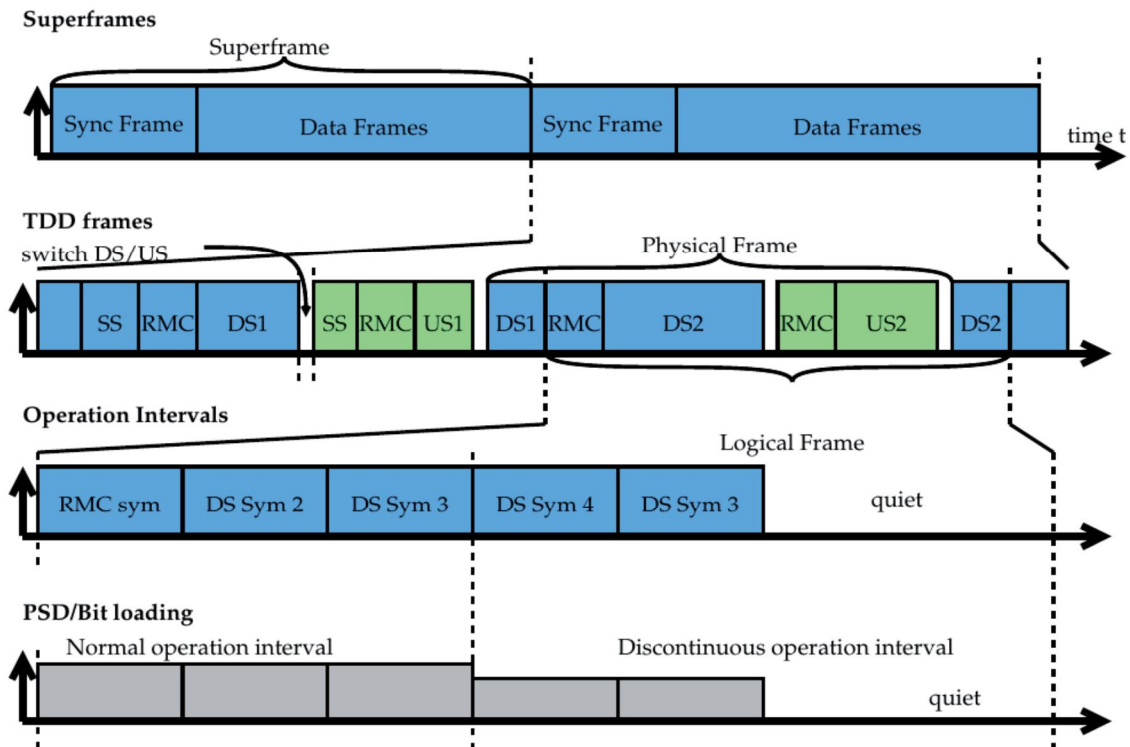

Figure: 19 The frame structure of G.fast

The downstream data symbol block and the upstream data symbol block are further split into a normal operation interval (NOI) and a discontinuous operation interval (DOI) where discontinuous operation can be applied. In the normal operation interval, all lines of a DP are active and transmit or receive data. During the discontinuous operation interval, the lines may stop transmitting to save power. In this time, the line drivers and analog front-ends may be switched off to save power. But in a multi-line distribution point with crosstalk cancellation, the signals cannot be treated independently which requires additional signal processing to facilitate discontinuous operation.

4.9 G.fast Management

G.fast management features are such as Time Division Duplexing, Fast Rate Adaptation, Seamless Rate Adaptation, On-Line Reconfiguration, Vectoring and discontinuous operation will have their own controls. This provides additional room for automatic line optimization for purposes of protecting against impulsive and time varying noise sources in the home environment. The use of reverse powering means that the DPU may lose power if all the CPE connected to it are turned off and no longer provide reverse power feed. The solution is to employ a Persistent Management Agent (PMA) located either in a continuously-powered part of the network, or preferably virtualized in the cloud. The PMA will store diagnostics data

from the DPU so these are available after the DPU is powered down. The PMA can also accept configuration changes and apply them after the DPU regains power. Finally, management of Remote Copper Reconfiguration (RCR) can avoid truck-rolls to the network equipment for installation and activation of new or upgraded broadband service. G.fast management interfaces are currently standardized (ITU-T G.997.2 : Physical layer management for G.fast transceivers).

5.0 Deployment Scenarios

Based on the three deployment scenarios, single-port-, multi-port-FTTdp and FTTC, the requirements on G.fast front-end electronics and the distribution point hardware are evaluated. A more detailed description of FTTdp deployment scenarios can be found in the Broadband Forum (BBF) document. This section gives a short overview over network properties where G.fast is applicable. It also answers the question, why copper access technologies are still an integral part of the fiber access network.

5.1 Fiber To The Home vs. Single Port FTTdp

Deployments with one fiber link per subscriber are the network topology for rural areas where the population is not too dense. G.fast can help to reduce deployment cost in such areas.

At a first glance, there is no copper access technology required to build a FTTH connection. But in practice, connecting the fiber directly to the customer premises causes some disadvantages that can be solved by the hybrid copper/fiber approach, where the fiber is extended with a single-port DP and a short copper wire.

- While fiber connections require a technician to install the customer premises equipment, the copper-based CPE may be installed by customer (customer self install), because the only action required installing the copper-based CPE is to connect the CPE to the phone plug with the delivered cable. This saves cost for new subscribers and makes the home installation much easier.
- In urban environments, deploying fibers to the subscriber homes may not be possible due to legal restrictions or because of difficulties to install fibers in existing buildings.
- Lead times can be unpredictable, particularly if permission for construction work is required from home owners and tenant associations

Single Port FTTdp is the easiest to implement from a DP box hardware perspective, but also the most expensive one. There is one fiber per subscriber which is very costly for the network operators.

Figure.20 shows some Single Port FTTdp deployment cases. The distribution point translates the signals from one fiber to one copper twisted pair. No crosstalk cancellation is required and the line length is short, in the range of 100m but in most cases much shorter. The distribution point is supplied from the customer side using reverse power feeding.

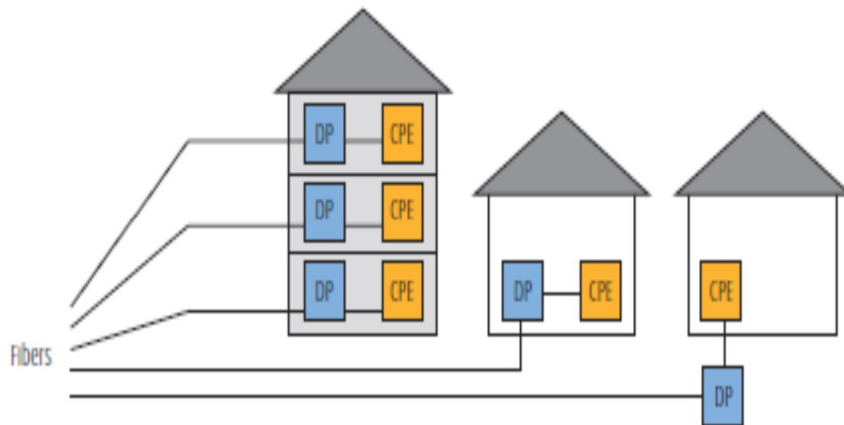

Figure 20: Single Port FTTdp applications

5.2 Multi-Port FTTdp and Fiber To The Building

FTTH deployments are very limited and cost is not the only reason for that. Multi-line distribution points are a smarter solution to provide fiber-speed services. Deployments with multi-line DPs are used in areas with a more dense population and multi-unit residential buildings.

- Most in-house telephone installations still rely on copper cables for most existing and newly constructed buildings because fibers are expensive and difficult to handle.
- The unbundled lines may not be accessible for the service provider to install individual DP boxes
- Especially in existing buildings, the copper wire bundles may be of a poor quality.

Besides in-building or in-home installations, there are different outdoor locations where the distribution point may be placed. Examples are manholes, pole-mounted distribution points or small street cabinets. The main advantage of FTTdp in comparison to existing FTTB solutions is reverse power feeding. It allows placing the DP box at any appropriate place, without the requirement of a local power supply.

Multi-line DPs with G.fast allow to deliver fiber-speed data rates under these conditions. While the line length of the copper wires is moderate, in most cases shorter than 100m and only in rare cases up to 250m and the cable binder are small, usually no more than 16 pairs. But cross-talk between the pairs limits the achievable data rates for a G.fast service.

Figure. 21 shows Multi-line FTTdp scenarios. The DP may be placed inside the building or outside, with one or more buildings connected. The subscribers of one DP share the data rate of one or more GPON links. For today's Vinax™ DP-based multi-port DP-boxes, the performance impact due to crosstalk is small. But for a G.fast-based DP box crosstalk cancelation becomes critical for performance. Crosstalk cancelation on twisted pair telephony wires at frequencies as high as 106 MHz or even 212 MHz opens a new field for innovation.

But for the development of improved crosstalk cancellation techniques, a good understanding of the cable behavior is very important as will be shown later. FTTB and multi-port FTTdp is not the most demanding environment for G.fast systems.

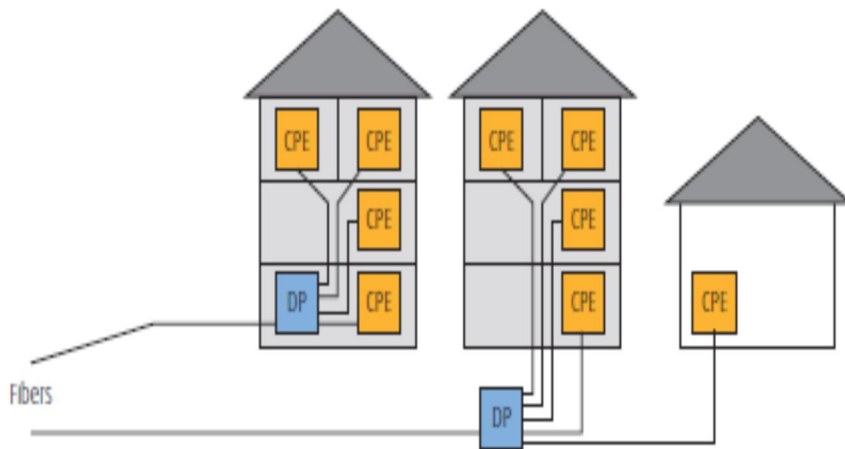

.Figure 21: Multi-port FTTdp deployment examples

5.3 Fiber to The Curb with G.fast

The transition from current VDSL technology to the new G.fast service is a very critical step, because in this time, VDSL and G.fast coexist in the network. Lantiq provides solutions to serve G.fast from the VDSL cabinet.

The next generation Vectoring chip supports crosstalk cancellation for up to 48 G.fast channels.

Street cabinets with G.fast support may serve G.fast and VDSL from one location, depending on the rate requirements and line length as shown in Fig. 22 (a). For manholes and pole-mounted distribution points, the VDSL signals may be provided from a street cabinet at some distance from the DP as shown in Fig. 22 (b).

For the G.fast FTTC, the G.fast reach is extended to 300m or even more. Subscriber lines with longer lines may exist in both FTTC scenarios, but they are served using VDSL and not G.fast. But for the scenario of Fig. 22 (a) with a multi-service cabinet, near-end crosstalk between G.fast and VDSL may become very strong. Therefore, near-end in addition to far-end crosstalk must be considered in the crosstalk scenario. A channel model is required to describe near-end and far-end crosstalk correctly.

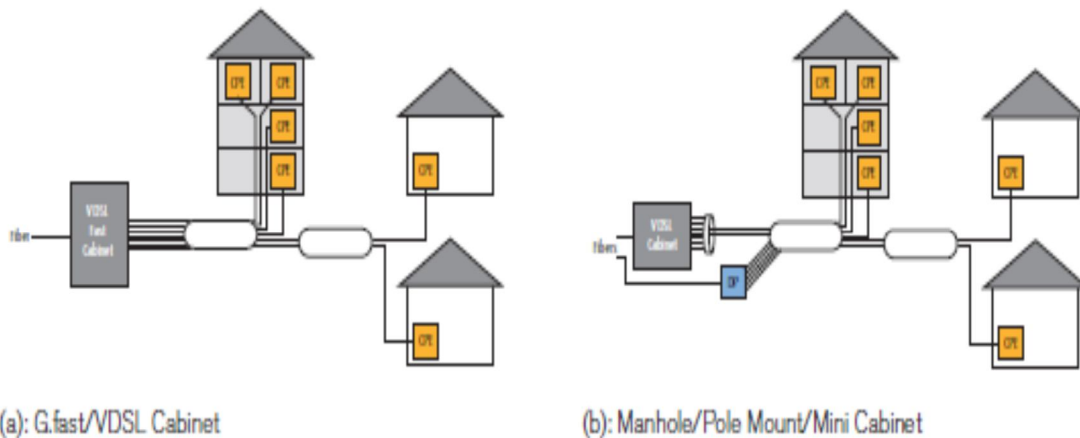

Figure 22 (a) & (b): G.fast topologies with VDSL coexistence

5.4 Deployment status worldwide:

The deployment of G.fast has started only in 2015, although the standard of G.fast were finalized long back. Following are the status of deployment in various countries:

- Swiss operator Swisscom tested its G.fast service in the small village of Bibern in April 2015, and has since extended these tests to a small portion of households throughout the country, offering speeds of up to 500Mbps. Swisscom is currently scaling-up its G.fast deployment.
- Alcatel-lucent and BT began an extensive consumer G.fast trial in the North-East of England in 2015.
- Australia’s NBN successfully completed its first trial of G.fast technology in 2015. The trial conducted in Carldo, Melbourne, achieved speeds of over 600 Mbps over 100 meters of existing copper wire. Service providers are due to begin G.fast trials during 2016, with commercial launch anticipated in 2017.
- Norwegian operator Homenet ran a G.fast pilot in Oslo in 2015 with a commercial launch planned for later this year, according to local reports.

G.fast was developed by Study Group 15, the ITU standardization expert group responsible for ‘Transport, Access and Home’. To learn more about the international standards developed by the group, see “[Study Group 15 at a glance.](#)”

Source: <https://itu4u.wordpress.com/2016/04/27/g-fast-providers-worldwide-step-up-trials-to-meet-broadband-demand/>

6.0 Conclusion:

FTTH is still viewed as the most future-proof access technology for high bandwidth services, though not without significant challenges presented by the final last mile; CAPEX-heavy household disruptions such as the running of fiber optic cables underground to the

household, which can require the digging up of the lawn or garden, as well as physical changes to the household itself, can make full FTTH deployment unappealing for service providers and consumers. The cost of consumer premise equipment can also present a financial burden, with the average sales price (ASP) of an ONT and router combination significantly higher than that of a DSL gateway.

G.Fast can provide an alternative to these last mile difficulties while still providing bandwidth speeds up to a gigabit. However, the promise of G.Fast gigabit service is highly dependent upon the distance of the copper loop line from the household. The technology requires the distribution point where the fiber optic cable terminates to be very close to the household for efficiency.

G.Fast technology reaches signal degradation at about 100 meters of vectored copper VDSL lines. For very short loops, less than 100 meters, it is possible to use G.Fast for gigabit services. Between 100 and 200 meters, bandwidth speeds of 300 – 500Mbps are possible. After 200m, signal degradation is so rapid that G.Fast becomes redundant.

G.Fast is a very efficient solution for multi-dwelling units in densely populated urban areas, as fiber can be run to the building, or even to the floor, with the end result being very short copper loop lines over which G.Fast performs at its best.

Additionally, FTTS, is a strategy in which the fiber optic cable is run to a cabinet in the street close to the household. If the ISP network topology is designed such that cabinets are within 200 meters of the households they serve, then broadband speeds up to 500Mbps can be served to those households over G.Fast technology.

References

1. G.Fast-A Paper by the Deployment & Operations Committee, Fibre to the Home Council Europe, Contributors: Eric Festraets, Alcatel-Lucent and Rong Zhao, Detecon
2. G.fast Technology and the FTTdp Network, Rainer Strobel, Lantiq
3. IEEE Communication magazine. January 2009,(The Fourth generation Broad Band Concept),Per Odling, Thomas Magesacher, Stefan Host, and Per Ola Borjesson, Lund University ,Migule Areizaga, Tecnalia-robotiker
4. MR-257 ,An Overview of G.993.5 Vectoring,Issue: 2 ,Issue Date: March 2014Broad Band Forum
5. ITU-T G.9700 Transmission Systems And Media, Digital Systems And Networks Access networks – Metallic access networks Fast access to subscriber terminals (G.fast) – Power spectral density specification Recommendation
6. ITU-T **G.9701** Fast access to subscriber terminals (G.fast) - Physical layer specification.
7. Wideband modeling of twisted-pair cables for MIMO application, Reinhard stole, Rainer Strobel and wolfgang utschick.

Abbreviations	
4GBB	Fourth Generation Broadband
ADSL	Asymmetric Digital Subscriber Line
ANFP	Access Network Frequency Plan
ASP	Average Sales Price
BBF	Broadband Forum
CAPEX	Capital Expenditure
CO	Central Office
DOI	Discontinuous Operation Interval
DP	Distribution Point
DPU	Distribution Point Unit
DMT	Distribution Modulation Technology
FAST	Fast Access to Subscriber Terminals
FDD	Frequency Division Duplex
FEC	Forward Error Correction
FEXT	Far-End Cross-Talk
FRA	Fast Rate Adaptation
FTTB	Fiber To The Building
FTTC	Fiber To The Curb
FTTdp	Fiber To The Distribution Point
FTTH	Fiber To The Home
G-PON	Gigabit-PON
INP	Impulse Noise Protection
ISDN	Integrated Services Digital Network
MIMO-	Multiple-Input Multiple-Output
NEXT	Near-end crosstalk
NOI	Normal Operation Interval
Of com	Office Of Communications
PMA	Persistent Management Agent
PON	Passive Optical Fiber Net-Work
PSDs	Power Spectral Densities
RPF	Reverse Power Feeding
RCR	Remote Copper Reconfiguration
RMC	Robust Management Channel
TDD	Time Division Duplex
VDSL	Very-High-Bit-Rate DSL